



OPERATING WATERBLASTING EQUIPMENT CAN BE POTENTIALLY HAZARDOUS. SEE PAGE 121 FOR IMPORTANT SAFETY INFORMATION

CURVED PIPE CLEANING

2" BADGER®

Rotary Cleaning for Small Pipes with Elbows

The 2" Badger is a self-rotating tool designed for cleaning 2–4 in. (51–102 mm) pipes with bends and long radius elbows such as U-Tubes and process lines. The latest design includes a spring-loaded pin that ratchets the head to machined edges on the shaft. Therefore, the head can only be removed with a special head removal tool, not while in operation.

FEATURES:

- The only self-rotary tool on the market that can navigate 2 in. (50 mm) pipes with bends
- The only tool in the industry with head locking technology for increased safety
- Multiple jetting options allow the tool to be optimized for a variety of pump pressures and flows. Unplug, polish, or run longer lines based on jetting
- Pair with the ABX-PRO for hands-free mole lining



NEW BA-530 FAIRING

Tool Model	Pressure Range	Flow Range	Inlet Connection	Weight	Max Water Temperature
BA-LK-P4 BA-LK-BSPP4	2–15k psi 140–1000 bar	3–20 gpm 11–76 l/min	1/4 NPT or 1/4 BSPP	0.45 lb 0.20 kg	250 °F 120 °C
BA-LK-MP9L BA-LK-MP9R	12–22k psi 830–1500 bar	3–15 gpm 11–57 l/min	9/16 MP or M24	0.45 lb 0.20 kg	250 °F 120 °C

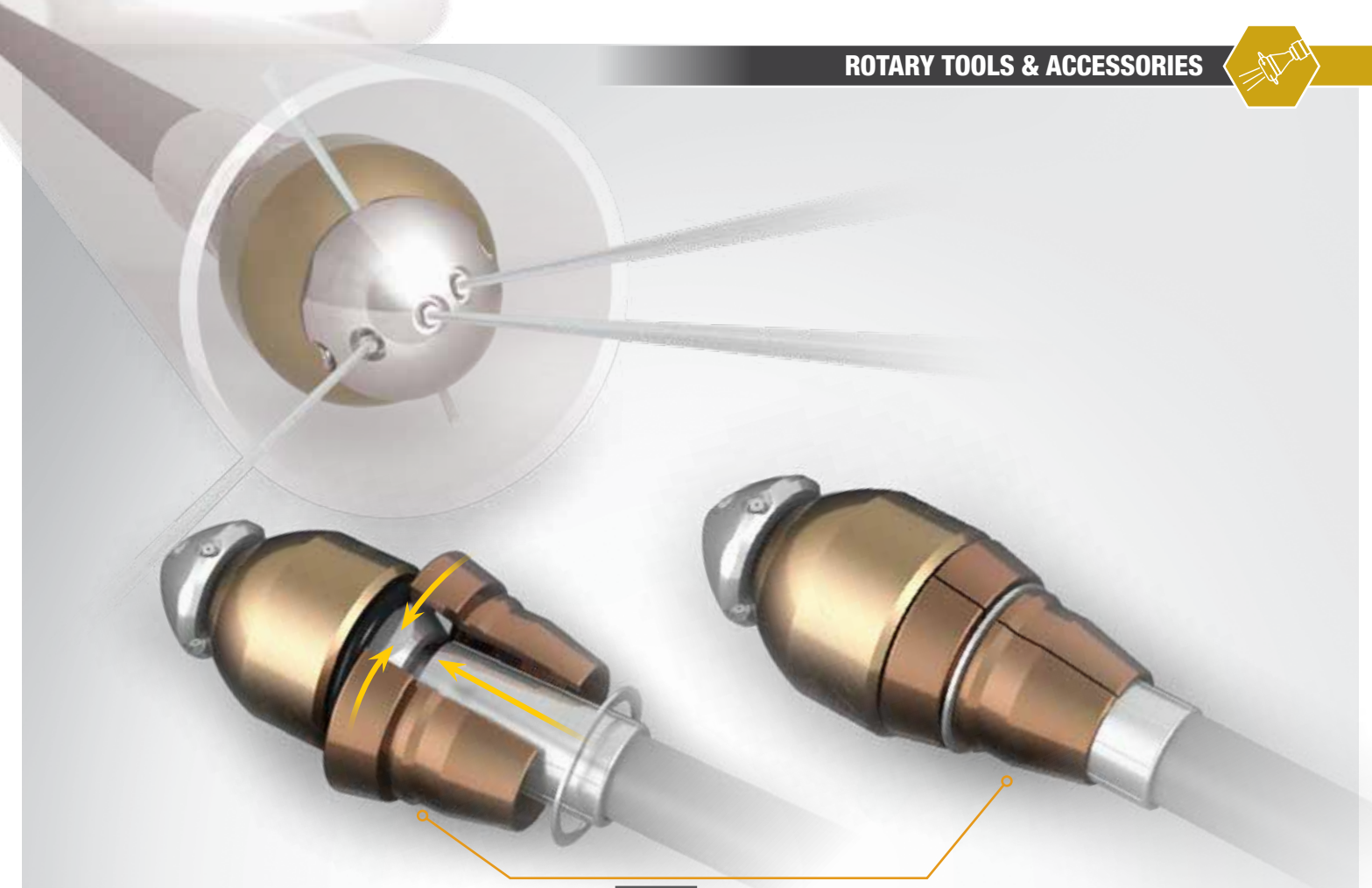

NEW BA-530 FAIRING

Specifically designed to be attached to the hose behind a 2" Badger rotary pipe cleaning tool.

The tapered sides of the fairing prevent the rear edge of the Badger from getting caught on obstructions when being removed from a pipe.

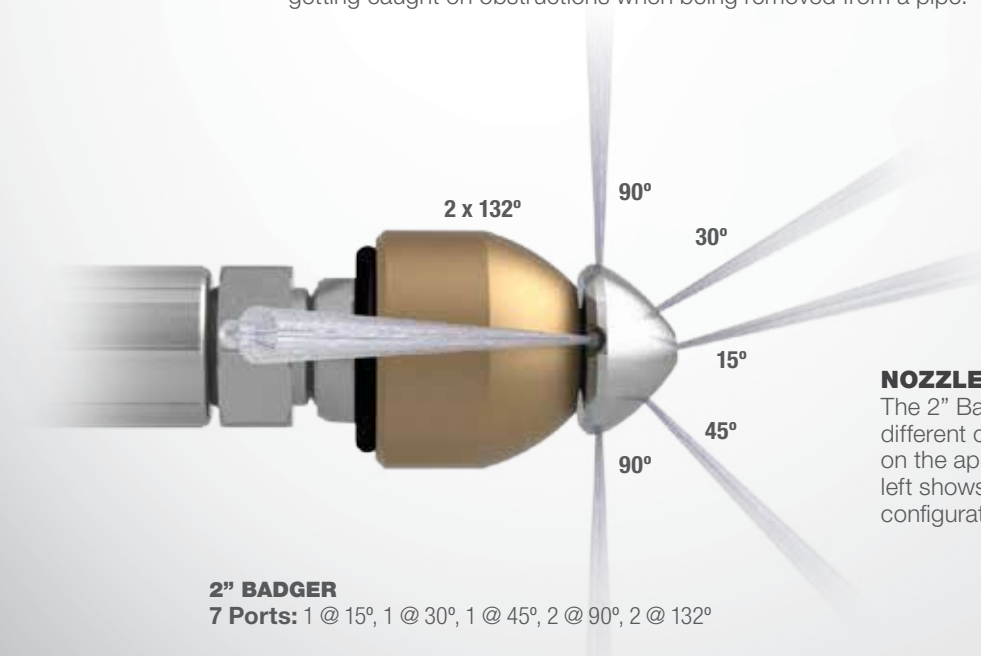

2" BADGER
7 Ports: 1 @ 15°, 1 @ 30°, 1 @ 45°, 2 @ 90°, 2 @ 132°

NOZZLES AND PLUGS

The 2" Badger can be jetted in different configurations depending on the application. The image to the left shows the standard nozzle/plug configuration for the 2" Badger tool.

Tool	Tool Kit	Manual
2" BADGER	BA 612-LK	PL 593