

OPERATING WATERBLASTING EQUIPMENT CAN BE POTENTIALLY HAZARDOUS.
SEE PAGE 121 FOR IMPORTANT SAFETY INFORMATION

FURNACE & BOILER CLEANING

BIG FLOW WATERLANCER (BFW-100)

The BFW-100 is an automated system designed for hands-free online boiler cleaning that enables contractors to reduce down time by cleaning at high temperatures. With a 300 gpm (1140 l/min) flow capability, the BFW-100 can effectively clean any large vessel with limited entry access.

The BFW-100 features an adjustable cart with an air-powered boom positioner and provides excellent cleaning for pulp plant boilers, refinery and chemical plant vessels, as well as furnace radiant sections.

FEATURES:

- Temperature resistant design reduces downtime by allowing cleaning operation while online
- Remote Control Box controls linear and rotation speeds from a safe distance
- Adjustable rail and cart allows for easy tool positioning, including elevation and angle of the lance
- Cantilever option available – accommodates lengths up to 24 ft (7.3 m)

IDEAL FOR:

- Pulp plant boilers
- Refinery and chemical plant vessels
- Furnace radiant sections
- Boiler floors

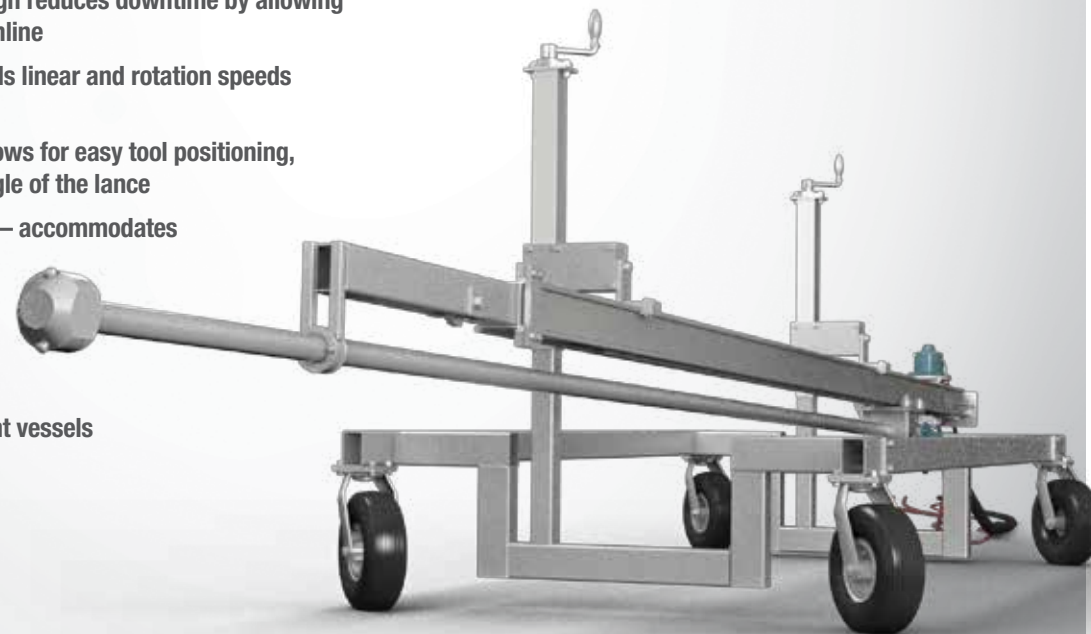

Tool Model	Pressure Range	Flow Range	Inlet Connection	Rotation Speed	Linear Speed	Stroke Length
BFW-100	10k psi 700 bar	300 gpm 1140 l/min	1 NPT	10–50 rpm	8–35 ft/min 2.4–11 m/min	13 ft 4.0 m



OPTIONS UP TO 24 FT.
Longer stroke lengths are possible with the Cantilever Boiler Long Snout system

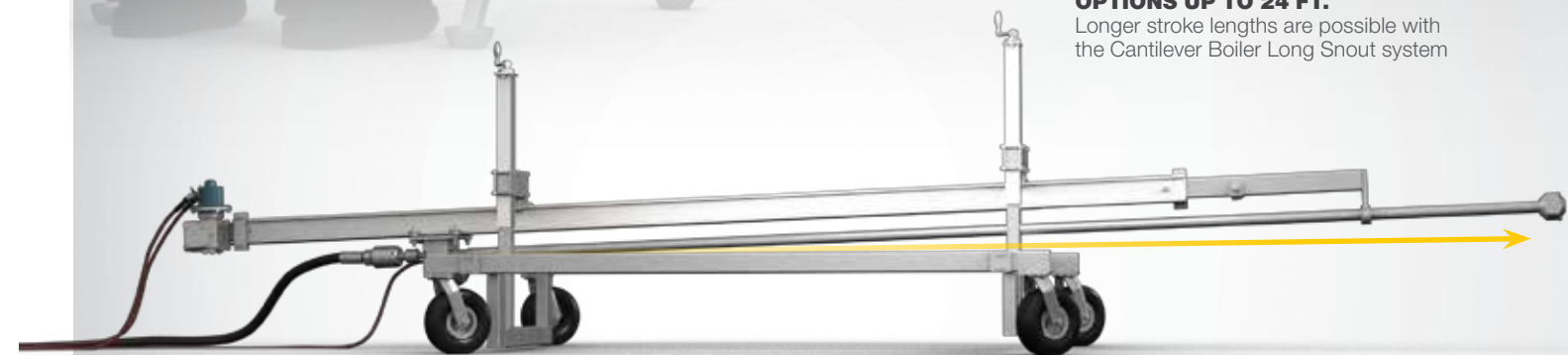

INDIVIDUAL HEIGHT ADJUSTMENTS
Allow precise placement of head to reach difficult areas within the boiler

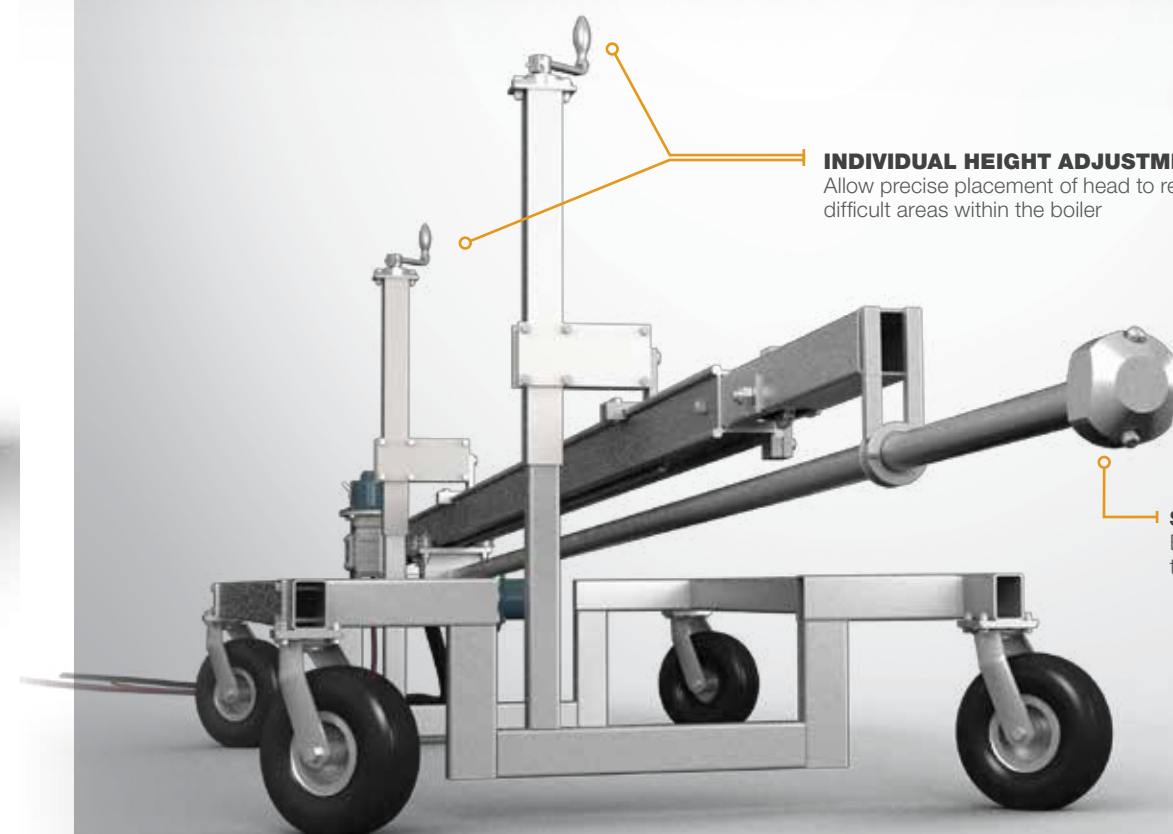

STAINLESS STEEL HEAD/NOZZLES
Excellent heat tolerance – highly resistant to chemicals and harsh environments