

# Barracuda® 44k psi (3000 bar) Shotgun Swivel X Low Flow (BC-H9-XLF-C)

## Description:

The Barracuda® BC-H9-XLF-C is a self-rotating swivel designed for handheld shotgun waterblast cleaning. It has a 9/16 high pressure cone and thread inlet port, with an easily replaced seal cartridge assembly. One head is available; refer to the charts for flow ranges and the correct nozzle sizes if using four jets. The head has 7/16-20 nozzle ports for sapphire nozzle assemblies. Two ports may be plugged if desired, but larger nozzles need to be used to maintain the same flow rate. It is best to use two larger jets for thick deposits such as concrete removal, and four jets for thin coatings or scale, as it allows the tool to be moved faster over the surface.

The Barracuda® BC-H9-XLF-C uses automatic transmission fluid (ATF) as a lubricant for the bearings and speed control components. It can be flushed / refilled with ATF through the fill port using a syringe. This is recommended after every 20 to 40 hours of operation.

The cartridge assembly can be rebuilt by replacing the high pressure seal; it is recommended to have at least one spare cartridge assembly on hand to quickly exchange, and keeping the operator from having to rebuild cartridges in the field.

Flow in gpm (lpm) for Extra Low Flow (BC-H9-XLF-C)						
Pressure, k psi (bar)	Nozzle ID, in.					
	.015	.016	.017	.018	.019	.020
28 (1950)		3.3 (12.7)	3.8 (14.3)	4.2 (16.0)	4.7 (17.9)	5.2 (19.8)
30 (2075)		3.4 (13.1)	3.9 (14.8)	4.4 (16.6)	4.9 (18.4)	5.4 (20.4)
32 (2200)		3.6 (13.4)	4.0 (15.2)	4.5 (17.0)	5.0 (19.0)	5.6 (21.0)
36 (2500)		3.8 (14.4)	4.3 (16.2)	4.8 (18.2)	5.3 (20.2)	
40 (2800)	3.5 (13.4)	4.0 (15.2)	4.5 (17.1)	5.0 (19.2)		
44 (3000)	3.7 (13.8)	4.2 (15.7)	4.7 (17.8)	5.3 (19.9)		

## Operation:

The Barracuda® should always be used with a gun that includes a dump or pressure shut-off mechanism, so that pressure can be rapidly released. The gun barrel length including the Barracuda® should be long enough that the gun operator cannot pass the jets over his feet or legs. It is recommended that the thrust produced by the jets be no more than 1/3 the weight of the operator. Install the desired nozzle size into the head; we recommend using Blue Goop on the nozzle threads. Attach the Barracuda® to the shotgun barrel. Flush the high pressure hose before connecting to the gun inlet. Check that the dump mechanism functions correctly before going to operating pressure. The Barracuda® high pressure seal may initially leak at lower pressure, but the seal should pop shut as pressure is increased. To set the operating pressure, the gun operator should close the dump on the gun, and the pump operator should slowly increase the pressure to allow the gun operator to compensate for the jet thrust. The Barracuda® head should be within 2 to 8 inches of the surface, depending on how difficult it is to remove the material.

## Troubleshooting:

**High Pressure Seal Leak:** If water is coming out of the single round hole in the body, it is the inlet connection that is leaking. If water is coming out of the slots in the body, it is the high pressure seal that is leaking. Remove the tool from the gun and remove the O-Ring (BJ 417) that holds in the cartridge. Replace the cartridge. A slight drip to small stream leakage may be present from the cartridge while the tool reaches pressure, this leak may gradually become present over time. This leakage is considered normal and should be eliminated when the tool reaches the full operating pressure as the dump or pressure shut-off mechanism is engaged.

**Seals wear out quickly:** Remove and inspect the cartridge parts. The carbide seat should be checked for chips or erosion marks on it. When the life of the high pressure seal becomes noticeably less, the seal retainer needs to be replaced. Also replace the carbide seat if it has not been replaced with each seal change. Very rarely, the spring that controls the speed of the tool will break, allowing the tool to spin too fast and quickly wear out the seal.

**Will not rotate:** Check the nozzles to see if they are plugged or partially plugged. To clean them, they must be removed from the head; it does not do any good to poke the material plugging the nozzle back into the head. Check that the nozzles are the correct size based on the chart above. If all of these things appear to be correct, the tool may need to be disassembled and repaired. If the tool has just been rebuilt, and the tool starts to spin but stops as pressure is increased, the bearings (RJ 007) are installed backwards and the tool must be disassembled and fixed.

## Maintenance:

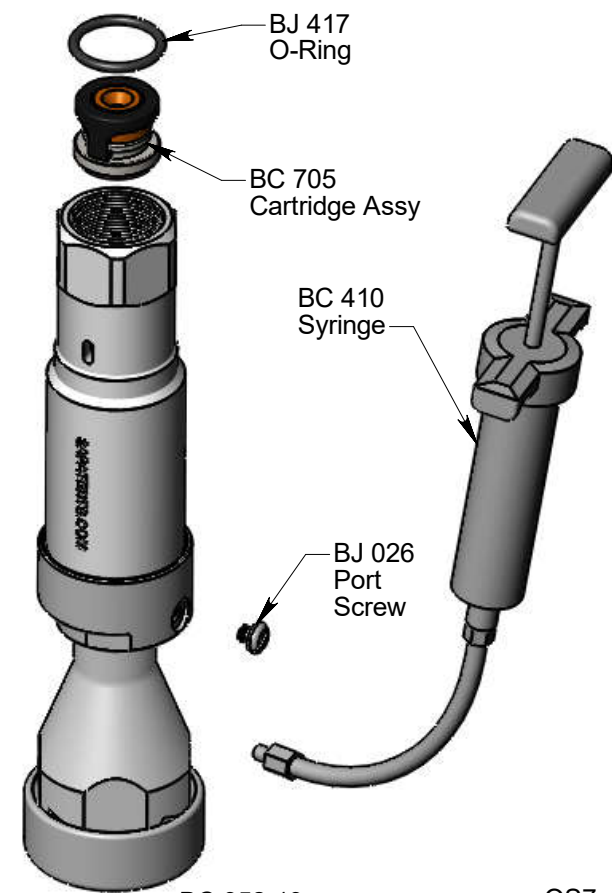

### To replace the cartridge:

1. Remove the O-Ring (BJ 417) from inlet port. It is easiest to push it upward from the round weep hole.
2. If necessary, use two picks inserted through the slots to pry the Cartridge Assy (BC 505-S) up and out of the Body.
3. Turn the swivel inlet end up; insert a fresh Cartridge Assy into the inlet port and re-insert the O-ring behind the Cartridge Assy to secure it in place.

**The Barracuda® uses ATF (automatic transmission fluid) for lubrication. It is recommended that a full syringe of fresh fluid be added to the swivel after every 20 to 40 hours of operation.**

1. Remove the Port Screw (BJ 026)
2. Thread the Syringe (BC 410) into the port.
3. Squeeze fresh ATF into the swivel; excess will come out the slots.
4. Remove Syringe and install Port Screw.

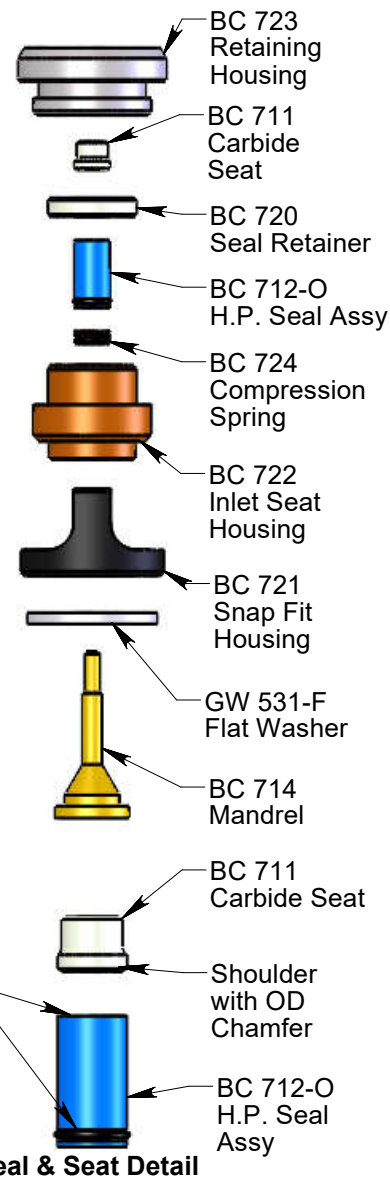

### To assemble the Cartridge Assy:

1. Place Mandrel (BC 714) on a flat surface.
2. Place Flat Washer (GW 531-F) onto Mandrel.
3. Install Snap Fit Housing (BC 721) onto Inlet Seat Housing (BC 722).
4. Stack the assembled Snap Fit Housing and Inlet Seat Housing with the internal cone at the bottom onto the Mandrel and Flat Washer.
5. Insert Compression Spring (BC 724) into bore of Inlet Seat Housing.
6. Place a small amount of Grease on the H.P. Seal Assy (BC 712-O) at the O-ring and Seal Face. Insert the H.P. Seal Assy into bore of Inlet Seat Housing making sure the end with the O-Ring and seal support goes in first. (see detail for orientation and grease locations)
7. Stack the Seal Retainer (BC 720) around the H.P. Seal Assy.
8. Stack the Carbide Seat (BC 711) making sure the shoulder with OD chamfered end is against the H.P. Seal. (see detail)
9. Slip the Retaining Housing (BC 723) over entire stack and press down firmly to engage the Snap Fit Housing.
10. Remove the Mandrel and Flat Washer and lightly press the backside of the exposed Carbide Seat to ensure free movement.

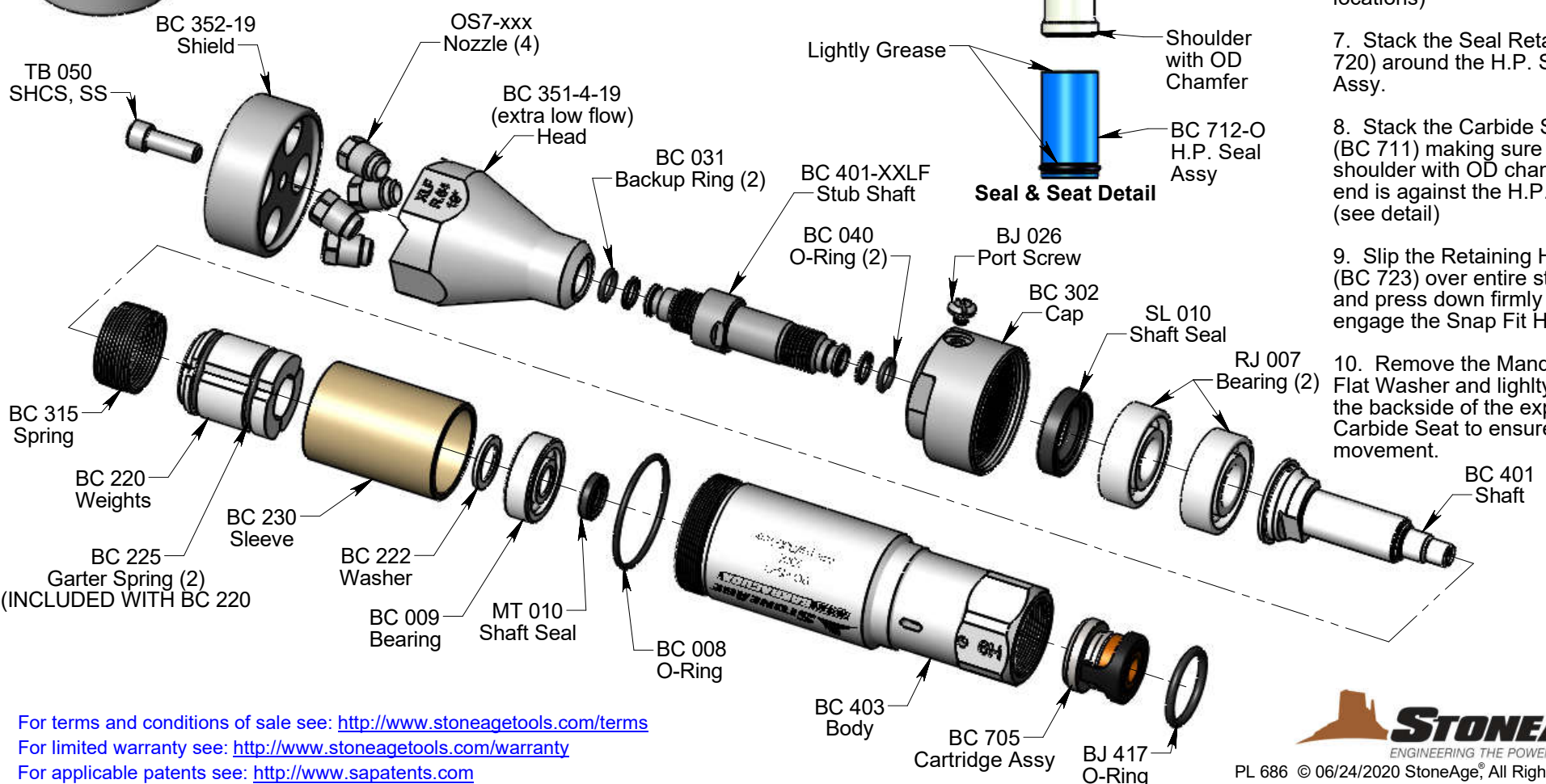



# Barracuda® 44k psi (3000 bar) Shotgun Swivel X Low Flow (BC-H9-XLF-C)

## Disassembly:

1. Remove the O-Ring (BJ 417) from the inlet port of the Body. Pry out the high pressure seal Cartridge Assy (BC 705) as explained in the Maintenance Section.
2. Unscrew the Body (BC 403) from the Cap (BC 302); remove the Sleeve (BC 230).
3. If the Shaft Seal (MT 010) is damaged, remove it from the Body using snap ring pliers.

4. Pull the Bearing (BC 009) from the Shaft. Remove the Washer (BC 222).
5. Unhook the Spring (BC 315) from the hole in the Shaft; remove the Weights (BC 220) and Spring (BC 315) from the Shaft. Leave the Weights together.
6. Unscrew the Shaft (BC 401) from the Stub Shaft (BC 401-XXLF) and pull up on the Cap (BC 302) to remove it and the Bearings (RJ 007) from the Stub Shaft.

7. If the Shaft Seal (SL 010) is damaged, remove it from the Cap. Remove the Port Screw (BJ 026).
8. Unscrew the Head from the Stub Shaft. Inspect the O-Rings (BC 040) and Backup Rings (BC 031) on the ends of the Stub Shaft. Remove them if they are damaged.

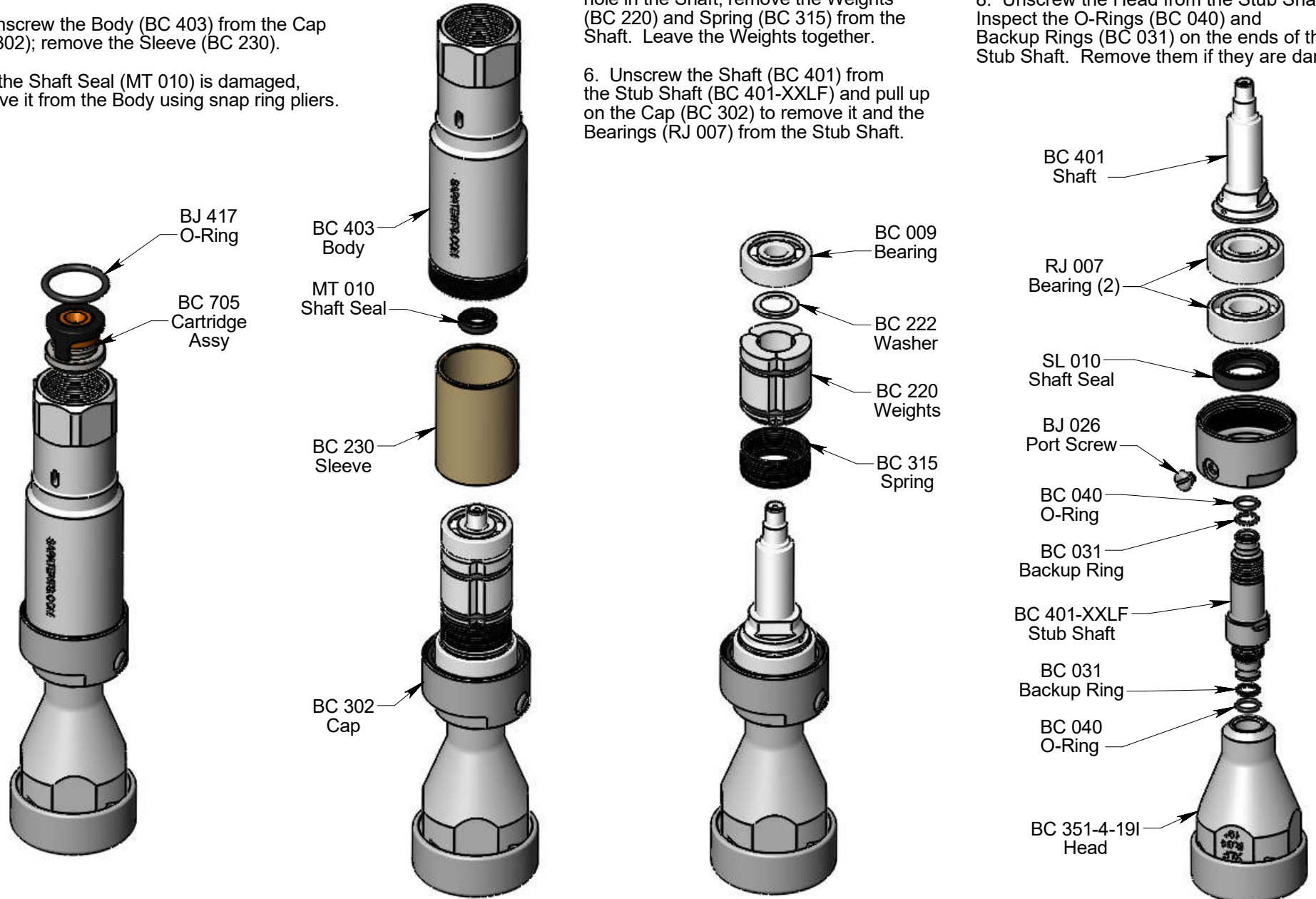

## Assembly:

1. Install Backup Rings (BC 031) and O-Rings (BC 040) on both ends of the Stub Shaft (BC 401-XXLF). Note order they sit. Apply anti-seize to threads and grease to O-Rings. Install Head onto Stub Shaft, tighten to 30 ft-lb.
2. Install Shaft Seal (SL 010) in Cap (BC 302). Apply Armour-All to lips of seal; slide Cap onto Head.
3. Install Bearings (RJ 007) on Stub Shaft. These are angular contact bearings and need to be installed as shown.
4. Thread Shaft (BC 401) onto Stub Shaft; tighten to 30 ft-lb.

5. Insert Spring (BC 315) end into hole in Weights (BC 220), then slide Weights and Spring onto Shaft; insert other spring end into hole in Shaft.
6. Place Washer (BC 222) on top of Weights, with chamfered face of washer facing toward Weights.
7. Slide Bearing (BC 009) onto Shaft. Slide Sleeve (BC 230) over the assembly.
8. Install O-Ring (BC 008) onto Body (BC 403).
9. Install Shaft Seal (MT 010) into Body.

10. Apply anti-seize to threads of Body; thread into Cap. Tighten to 45 ft-lb.
11. Install the high pressure seal Cartridge Assy as shown in the Maintenance Section.
12. Fill the tool with ATF as shown in the Maintenance Section. Install Port Screw (BJ 026).
13. Install Shield (BC 352-24) and tighten onto head with SHCS (GS 325-055).

