

BANSHEE

Rotary Tube Cleaning



2.6–6.9 in. 65–180 mm

The Banshee line of tube cleaning tools use high pressure water as a liquid bearing, replacing ball bearings, seals or lubricant used in conventional rotary tools. This patented design features a straight flow path that delivers the highest quality jets for maximum cleaning power.

Banshee tools clean effectively at a wide range of pressures up to 40,000 psi (2800 bar). Each tool can be easily configured to suit any application by choosing from a variety of replaceable heads and inlet options.

COMPETITIVE ADVANTAGES

- Proven to be the most effective tube cleaning tools on the market
- Low cost, low maintenance bearing design
- Extensive tool selection for all major hose sizes and tube cleaning applications
- Multiple interchangeable head options for polishing, unplugging, and different flow capacities
- Replaceable sapphire inserts on 40k psi models
- Easy to pair with automated flex lance machines

FEATURES	BENEFITS
<ul style="list-style-type: none"> • Patented liquid bearing technology 	<ul style="list-style-type: none"> • No bearings, seals or lubricant to replace — reduced maintenance costs
<ul style="list-style-type: none"> • Configurable head options 	<ul style="list-style-type: none"> • Select the most effective cleaning configuration for a specific application
<ul style="list-style-type: none"> • Streamlined internal flow path 	<ul style="list-style-type: none"> • Unlike labyrinth seal and cross jet pattern nozzles, Banshee tools deliver water in a straight path, generating the least amount of turbulence and highest quality jet power for better cleaning
<ul style="list-style-type: none"> • Shrouded head option (for use with automated drive equipment) 	<ul style="list-style-type: none"> • Allows the head to continue to rotate when forced against a blockage

BANSHEE TOOL OVERVIEW

QUESTIONS TO ASK YOUR CUSTOMER

- What size and length of hose are you using?
- What pressure and flow are you operating?
- What are the length and diameter of tubes?
- What type of cleaning is required? Are the tubes plugged?
- Do you need an adapter?
- Do you need a stinger?
- Do you need a backout preventer?
You should always use a backout preventer with high pressure tube cleaning tools.

OTHER INFORMATION

- The Banshee is a water-bearing tool, which means that the tool relies on a very thin “film” of water between shaft and body. It is critical that all lines are flushed prior to use to eliminate any debris which can cause the tool to misoperate.
- Water must be blown out of the Banshee after each use to avoid corrosion damage. It is also important to soak or bathe the tool in a very light oil such as WD-40 between applications.
- Pipe threads are rated to 15k psi (1000 bar) MAWP, M7 and MP threads are 22k psi (1500 bar) MAWP. Some BSP threads can rate as high as 22k psi (1500 bar), please refer to the tool manual for pressure ratings for each tool.
- Choose the appropriate head option for all cleaning applications. A universal head may not unplug or polish as effectively as the unplugging or polisher head specifically. Contact your StoneAge Customer Service for questions about specific applications, including the shrouded head option.
- StoneAge recommends the Banshee ProTex splash guard/back-out preventer for vertical applications and the VE-400 Safety Stop for horizontal or vertical back-out prevention.
- The use of pipe wrenches and or pliers with “teeth” will void all tool warranty. All Banshee tube cleaning tools require the use of a correctly sized open-end wrench to fit the flats provided on the inlet nut when attaching the tool to the lance. Incorrect tools can crush or crack the hardened steel body, leading to failure or breakage during operation.

BACKOUT PREVENTION

We offer two standard backout preventers to be used with all Banshee tool models.

The **VE-400 Safety Stop** is designed to protect the operator from a flex-lance exiting the tube sheet during cleaning operations.

The **Banshee ProTex BPT-100** vertical splashguard is lightweight and durable to keep operators safe from the potential hazards of flex-lancing.

TOOL SPECIFICATIONS — 22K PSI (1500 BAR) MODELS

PART ID	BN9.5	BN13, BNS13	BN15	BN18	BN24	BN33
Tube ID Range	0.47–0.63 in. 12–16 mm	0.60–1.0 in. 15–25 mm	0.75–1.2 in. 19–30 mm	0.87–1.3 in. 22–33 mm	1.1–2.0 in. 28–51 mm	1.5–2.4 in. 38–60 mm
Pressure Range*	10k–22k psi 700–1500 bar	8k–22k psi 550–1500 bar	8k–22k psi 550–1500 bar	8k–22k psi 550–1500 bar	8k–22k psi 550–1500 bar	8k–22k psi 550–1500 bar
Flow Range	5–6 gpm 19–23 l/min	7–9 gpm 26–34 l/min	8–10 gpm 30–38 l/min	8–14 gpm 30–53 l/min	11–24 gpm 42–91 l/min	11–48 gpm 42–182 l/min
Flow Coefficient	0.20 Cv	0.27 Cv	0.35 Cv	0.66 Cv	0.90 Cv	2.3 Cv
Inlet Connections	M7, 1/16 NPT	1/8 NPT, 1/8 BSPP, 1/4 LH, 1/4 RH, 3/8 LH, 3/8 RH	1/8 NPT, 1/8 BSPP, 3/8 LH/RH	1/4 NPT, 1/4 BSPP, 9/16 LH, 9/16 RH	3/8 NPT, 3/8 BSPP, 9/16 LH, 9/16 RH	1/2 NPT, 1/2 BSPP or 9/16 MP
Swivel Diameter	0.4 in. 10 mm	0.5 in. 13 mm	0.6 in. 15 mm	0.7 in. 18 mm	0.9 in. 24 mm	1.3 in. 33 mm
Swivel Length	2.6 in. 65 mm	2.9 in. 74 mm	3.0 in. 76 mm	3.8 in. 97 mm	5.1 in. 130 mm	6.9 in. 180 mm
Swivel Weight	0.05 lb 0.02 kg	0.10 lb 0.05 kg	0.15 lb 0.07 kg	0.25 lb 0.11 kg	0.60 lb 0.27 kg	1.8 lb 0.81 kg
Head Weight	0.01 lb .005 kg	0.05 lb 0.02 kg	0.08 lb 0.04 kg	0.08 lb 0.04 kg	0.10 lb 0.05 kg	0.25 lb 0.11 kg
Maximum Water Temperature	250 °F 120 °C	250 °F 120 °C	250 °F 120 °C	250 °F 120 °C	250 °F 120 °C	250 °F 120 °C

*The maximum working pressure for different Banshee swivels is dependent on the inlet connection.

TOOL SPECIFICATIONS — 40K PSI (2800 BAR) MODELS

PART ID	BN13-40K	BN18-40K	BN27-40K
Tube ID Range*	0.60–1.0 in. 15–25 mm	0.87–1.3 in. 22–33 mm	1.25–2.0 32–51 mm
Pressure Range	20–40k psi 1400–2800 bar	20–40k psi 1400–2800 bar	20–40k psi 1400–2800 bar
Flow Range	4.5–6 gpm 17–23 l/min	5–8.5 gpm 19–32 l/min	5–8.5 gpm 19–32 l/min
Flow Coefficient	0.20 Cv	0.25 Cv	0.30 Cv
Port Size	6-40 UNF (S2)	6-40 UNF (S2)	6-40 UNF (S2)
Nozzle Type	OS2	OS2	OS2
Inlet Connections	1/4 LH, 3/8 LH	3/8 LH, M14L, 9/16 LH, 9/16 RH	9/16 LH, M14L
Swivel Diameter	0.5 in. 13 mm	0.7 in. 18 mm	1.06 in. 27 mm
Swivel Length	3.5 in. 89 mm	4.7 in. 120 mm	5.5 in. 140 mm
Swivel Weight	0.15 lb 0.07 kg	0.30 lb 0.14 kg	0.10 lb 0.05 kg
Head Weight	0.05 lb 0.02 kg	0.08 lb 0.04 kg	0.15 lb 0.68 kg
Maximum Water Temperature	250 °F 120 °C	250 °F 120 °C	250 °F 120 °C

*When cleaning 5/8 in. diameter tubes at 40k psi, please contact our technical support team for hose specifications.

BANSHEE TOOL CONFIGURATION

MODELS UP TO 22K PSI (1500 BAR)

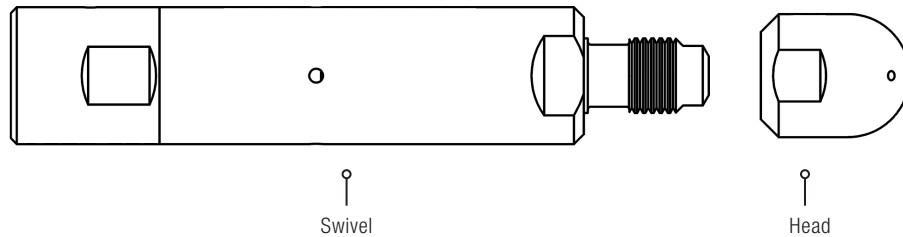

40K PSI (2800 BAR) MODELS

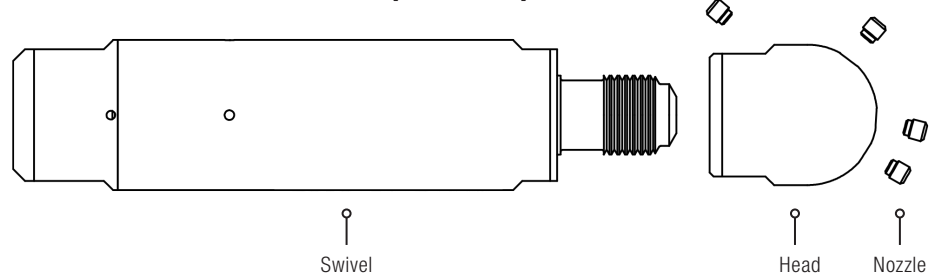

A complete Banshee tool configuration requires the following components:

1. Swivel for required working pressure and inlet connection
2. Head with required jet configuration, pressure and flow

The following items may also be required:

- Suitable hose adapter
- Backout preventer

To configure a Banshee tool, the following information should be obtained:

- Pump pressure and flow
- Hose length and ID
- Hose/lance end fitting

BANSHEE BN9.5

ORDERING A STANDARD PACKAGE

StoneAge offers standardized Banshee BN9.5 tool packages for the most commonly used configurations. All Banshee BN9.5 packages come fully assembled and include 1. Swivel, 2. Head.

The following table shows the configurations of standard Banshee BN9.5 tool packages:

MAXIMUM PRESSURE	INLET CONNECTION	PACKAGE CONTENTS	PACKAGE PART ID
15k psi 1000 bar	1/16 NPT Female	1 x BN9.5 Banshee swivel 1 x Polisher head	BN9.5-NPT-POL-PKG
		1 x BN 9.5 Banshee swivel 1 x Universal head	BN9.5-NPT-UNI-PKG
		1 x BN9.5 Banshee swivel 1 x Unplugging head	BN9.5-NPT-UNP-PKG
22k psi 1500 bar	M7 Female	1 x BN9.5 Banshee swivel 1 x Polisher head	BN9.5-M7-POL-PKG
		1 x BN 9.5 Banshee swivel 1 x Universal head	BN9.5-M7-UNI-PKG
		1 x BN9.5 Banshee swivel 1 x Unplugging head	BN9.5-M7-UNP-PKG
	1/4 LH Female, 1/4 RH Female	1 x BN9.5 Banshee swivel 1 x Polisher head	BN9.5-MP-POL-PKG
		1 x BN 9.5 Banshee swivel 1 x Universal head	BN9.5-MP-UNI-PKG
		1 x BN9.5 Banshee swivel 1 x Unplugging head	BN9.5-MP-UNP-PKG

When ordering a standard Banshee package, you should specify:

1. Package Part ID and inlet connection thread
2. Pump pressure and flow
3. Hose length and ID

FOR EXAMPLE:

QTY	PART ID	DESCRIPTION
1	BN9.5-MP-UNP-PKG	BN9.5 package 1/4 LH inlet. 20,000 psi 6 gpm 30 ft 5/32" ID

BANSHEE BN9.5

ORDERING BY LINE ITEM

Complete tools can be configured by following the steps outlined below.
 Contact your StoneAge Customer Service for questions about specific applications.

STEP 1 SWIVEL SELECTION

There are four Banshee BN9.5 swivel options available. The correct swivel is selected based on the maximum working pressure and inlet connection required.

MAXIMUM PRESSURE	INLET CONNECTION	SWIVEL PART ID
15k psi 1000 bar	1/16 NPT Female	BN9.5-P1
22k psi 1500 bar	M7 Female	BN9.5-M7
	1/4 LH Female	BN9.5-MP4L
	1/4 RH Female	BN9.5-MP4R

STEP 2 HEAD SELECTION

There are three standard head configurations for the BN9.5 swivel. Custom heads are available on request.

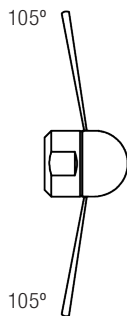

POLISHER

2 Ports:
2 @ 105°

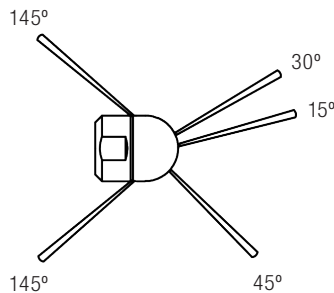

UNPLUGGER

5 Ports:
1 @ 15°
1 @ 30°
1 @ 45°
2 @ 145°

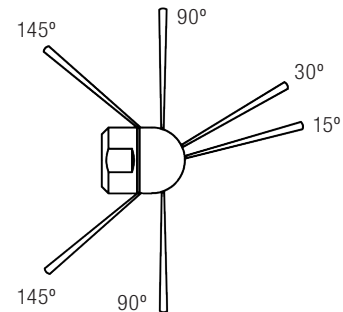

UNIVERSAL

6 Ports:
1 @ 15°
1 @ 30°
2 @ 90°
2 @ 145°

The following table lists head selection approximations of common jetting scenarios for Banshee BN9.5 swivels:

SWIVEL	HEAD STYLE	PRESSURE RANGE	FLOW RANGE	HEAD PART ID
BN9.5	Polisher	10–15k psi 700–1000 bar	5–6 gpm 19–23 l/min	BN9.5 042-A
		15–22k psi 1000–1500 bar	5–6 gpm 19–23 l/min	BN9.5 042-B
	Unplugging	10–15k psi 700–1000 bar	5–6 gpm 19–23 l/min	BN9.5 043-A
		15–22k psi 1000–1500 bar	5–6 gpm 19–23 l/min	BN9.5 043-B
	Universal	15–22k psi 1000–1500 bar	7–8 gpm 27–30 l/min	BN9.5 044-1

STEP 3 MAINTENANCE RESOURCES

StoneAge provides a tool kit for the Banshee BN9.5. This kit contains required wrenches for the BN9.5 swivel.

SWIVEL	TOOL KIT	MANUAL
BN9.5 (22k)	BN9.5 612	PL 505

Kit components and tool maintenance/assembly videos are available on the StoneAge website:

WWW.STONEAGETOOLS.COM

For questions or help with a specific application, configuration or tool repairs, please contact your StoneAge Customer Service.

When ordering a Banshee BN9.5 tool by line item, you should specify:

1. Swivel Part ID
2. Head Part ID
3. Part IDs of spare heads or maintenance items, if required

FOR EXAMPLE:

QTY	PART ID	DESCRIPTION
1	BN9.5-M7	Banshee swivel 9.5 mm M7 connection
3	BN9.5 042-A	Polisher head
3	BN9.5 043-A	Unplugging head

BANSHEE BN13

ORDERING A STANDARD PACKAGE

StoneAge offers standardized Banshee BN13 tool packages for the most commonly used configurations. All Banshee BN13 packages come fully assembled and include 1. Swivel, 2. Head.

The following table shows the configurations of standard Banshee BN13 tool packages:

MAXIMUM PRESSURE	INLET CONNECTION	PACKAGE CONTENTS	PACKAGE PART ID
15k psi 1000 bar	1/8 NPT Female	1 x BN13 Banshee swivel 1 x Polisher head	BN13-NPT-POL-PKG
		1 x BN13 Banshee swivel 1 x Universal head	BN13-NPT-UNI-PKG
		1 x BN13 Banshee swivel 1 x Unplugger head	BN13-NPT-UNP-PKG
18k psi 1250 bar	1/8 BSPP Female	1 x BN13 Banshee swivel 1 x Polisher head	BN13-BSPP-POL-PKG
		1 x BN13 Banshee swivel 1 x Universal head	BN13-BSPP-UNI-PKG
		1 x BN13 Banshee swivel 1 x Unplugger head	BN13-BSPP-UNP-PKG
22k psi 1500 bar	1/4 LH Female, 1/4 RH Female, 3/8 LH Female, 3/8 RH Female	1 x BN13 Banshee swivel 1 x Polisher head	BN13-MP-POL-PKG
		1 x BN13 Banshee swivel 1 x Universal head	BN13-MP-UNI-PKG
		1 x BN13 Banshee swivel 1 x Unplugger head	BN13-MP-UNP-PKG
40k psi 2800 bar	1/4 LH Female, 1/4 RH Female, 3/8 LH Female, 3/8 RH Female	1 x BN13 Banshee swivel 1 x Polisher head	BN13-HP-POL-PKG
		1 x BN13 Banshee swivel 1 x Unplugger head	BN13-HP-UNP-PKG

When ordering a standard Banshee BN13 package, you should specify:

1. Package Part ID and inlet connection thread
2. Pump pressure and flow
3. Hose length and ID

FOR EXAMPLE:

QTY	PART ID	DESCRIPTION
1	BN13-BSPP-UNI-PKG	BN13 universal package 1000 Bar 30 l/min 10 m 5 mm ID hose 1/8 BSPP

ORDERING BY LINE ITEM

Complete tools can be configured by following the steps outlined below.
Contact your StoneAge Customer Service for questions about specific applications.

STEP 1 SWIVEL SELECTION

There are ten Banshee BN13 swivel options available. The correct swivel is selected based on the maximum working pressure and inlet connection required.

MAXIMUM PRESSURE	INLET CONNECTION	SWIVEL PART ID
15k psi 1000 bar	1/8 NPT Female	BN13-P2
18k psi 1250 bar	1/8 BSPP Female	BN13-BSPP2
22k psi 1500 bar	1/4 LH Female	BN13-MP4L
	1/4 RH Female	BN13-MP4R
	3/8 LH Female	BN13-MP6L
	3/8 RH Female	BN13-MP6R
40k psi 2800 bar	1/4 LH Female	BN13-H4L
	1/4 RH Female	BN13-H4R
	3/8 LH Female	BN13-H6L
	3/8 RH Female	BN13-H6R

STEP 2 HEAD SELECTION

There are three standard head configurations for the BN13 swivel. Custom heads are available on request.

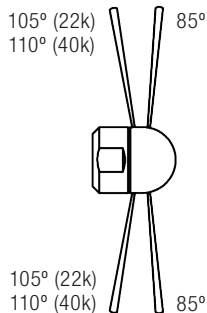

POLISHER
4 Ports:
2 @ 85°
2 @ 105°
(22k psi/1500 bar models)
— or —
2 @ 110°
(40k psi/2800 bar models)

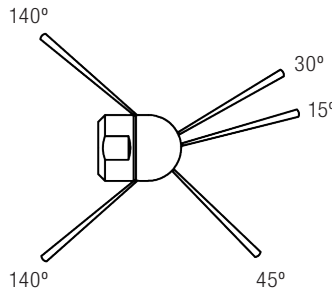

UNPLUGGER
5 Ports:
1 @ 15°
1 @ 30°
1 @ 45°
2 @ 140°

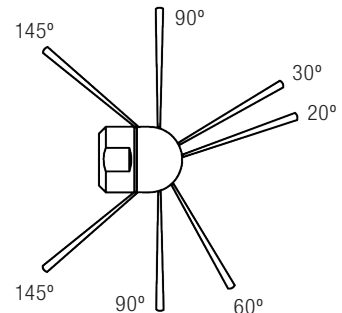

UNIVERSAL
7 Ports:
1 @ 20°
1 @ 30°
1 @ 60°
2 @ 90°
2 @ 145°

BANSHEE BN13

The following table lists head selection approximations of common jetting scenarios for Banshee BN13 swivels:

SWIVEL	HEAD STYLE	PRESSURE RANGE	FLOW RANGE	HEAD PART ID	NOZZLES FITTED	
					FRONT	BACK
BN13	Polisher	8–15k psi 550–1000 bar	7–9 gpm 27–34 l/min	BN13 042-A	N/A	N/A
		12–22k psi 830–1500 bar	7–9 gpm 27–34 l/min	BN13 042-C	N/A	N/A
		30–40k psi 2100–2800 bar	5.5–6 gpm 21–23 l/min	BN13 442-C	2 x OS2 014	2 x OS2 015
			4.5–5 gpm 17–19 l/min	BN13 442-D	2 x OS2 010	2 x OS2 014
	Unplugging	8–15k psi 550–1000 bar	7–9 gpm 27–34 l/min	BN13 043-A	N/A	N/A
		12–22k psi 830–1500 bar	7–9 gpm 27–34 l/min	BN13 043-C	N/A	N/A
		30–40k psi 2100–2800 bar	5.5–6 gpm 21–23 l/min	BN13 443-C	3 x OS2 010	2 x OS2 016
			4.5–5 gpm 17–19 l/min	BN13 443-D	3 x OS2 009	2 x OS2 015
	Universal	8–15k psi 550–1000 bar	8–10 gpm 30–38 l/min	BN13 044-A	N/A	N/A
		12–22k psi 830–1500 bar	7–8 gpm 27–30 l/min	BN13 044-C	N/A	N/A

STEP 3 MAINTENANCE RESOURCES

StoneAge provides a tool kit for the Banshee BN13. This kit contains required wrenches for the BN13 swivel.

SWIVEL	TOOL KIT	MANUAL
BN13 (22k)	BN13 612	PL 505
BN13 (40k)	BN13 612-H	PL 507

Kit components and tool maintenance/assembly videos are available on the StoneAge website:

WWW.STONEAGETOOLS.COM

For questions or help with a specific application, configuration or tool repairs, please contact your StoneAge Customer Service.

BANSHEE BN15

ORDERING A STANDARD PACKAGE

StoneAge offers standardized Banshee BN15 tool packages for the most commonly used configurations. All Banshee BN15 packages come fully assembled and include 1. Swivel, 2. Head.

The following table shows the configurations of standard Banshee BN15 tool packages:

MAXIMUM PRESSURE	INLET CONNECTION	PACKAGE CONTENTS	PACKAGE PART ID
15k psi 1000 bar	1/8 NPT Female	1 x BN15 Banshee swivel 1 x Polisher head	BN15-NPT-POL-PKG
		1 x BN15 Banshee swivel 1 x Universal head	BN15-NPT-UNI-PKG
		1 x BN15 Banshee swivel 1 x Unplugging head	BN15-NPT-UNP-PKG
18k psi 1250 bar	1/8 BSPP Female	1 x BN15 Banshee swivel 1 x Polisher head	BN15-BSPP-POL-PKG
		1 x BN15 Banshee swivel 1 x Universal head	BN15-BSPP-UNI-PKG
		1 x BN15 Banshee swivel 1 x Unplugging head	BN15-BSPP-UNP-PKG
22k psi 1500 bar	1/4 LH Female, 1/4 RH Female, 3/8 LH Female, 3/8 RH Female	1 x BN15 Banshee swivel 1 x Polisher head	BN15-MP-POL-PKG
		1 x BN15 Banshee swivel 1 x Universal head	BN15-MP-UNI-PKG
		1 x BN15 Banshee swivel 1 x Unplugging head	BN15-MP-UNP-PKG

When ordering a standard Banshee BN15 package, you should specify:

1. Package Part ID and inlet connection thread
2. Pump pressure and flow
3. Hose length and ID

FOR EXAMPLE:

QTY	PART ID	DESCRIPTION
1	BN15-MP-UNP-PKG	BN15 unplugging package 30 ft 3/16 ID hose 3/8 LH

BANSHEE BN15

ORDERING BY LINE ITEM

Complete tools can be configured by following the steps outlined below.
 Contact your StoneAge Customer Service for questions about specific applications.

STEP 1 SWIVEL SELECTION

There are six Banshee BN15 swivel options available. The correct swivel is selected based on the maximum working pressure and inlet connection required.

MAXIMUM PRESSURE	INLET CONNECTION	SWIVEL PART ID
15k psi 1000 bar	1/8 NPT Female	BN15-P2
18k psi 1250 bar	1/8 BSPP Female	BN15-BSPP2
22k psi 1500 bar	3/8 LH Female	BN15-MP6L
	3/8 RH Female	BN15-MP6R

STEP 2 HEAD SELECTION

There are three standard head configurations for the BN15 swivel. Custom heads are available on request.

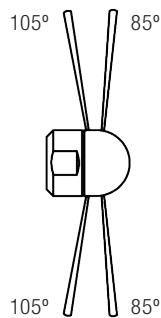

POLISHER

4 Ports:
 2 @ 85°
 2 @ 105°

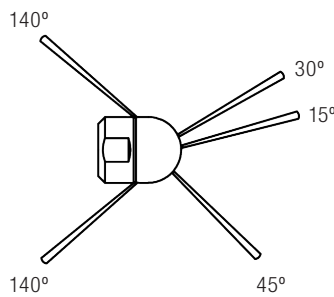

UNPLUGGER

5 Ports:
 1 @ 15°
 1 @ 30°
 1 @ 45°
 2 @ 145°

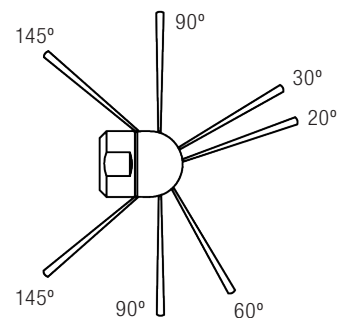

UNIVERSAL

7 Ports:
 1 @ 20°
 1 @ 30°
 1 @ 60°
 2 @ 90°
 2 @ 145°

The following table lists head selection approximations of common jetting scenarios for Banshee BN15 swivels:

SWIVEL	HEAD STYLE	PRESSURE RANGE	FLOW RANGE	HEAD PART ID
BN15	Polisher	8–15k psi 550–1000 bar	8–10 gpm 30–38 l/min	BN15 042-A
		12–22k psi 830–1500 bar	8–10 gpm 30–38 l/min	BN15 042-C
	Unplugger	8–15k psi 550–1000 bar	8–10 gpm 30–38 l/min	BN15 043-A
		12–22k psi 830–1500 bar	8–10 gpm 30–38 l/min	BN15 043-C
	Universal	8–15k psi 550–1000 bar	8–10 gpm 30–38 l/min	BN15 044-A
		12–22k psi 830–1500 bar	8–10 gpm 30–38 l/min	BN15 044-C

STEP 3 MAINTENANCE RESOURCES

StoneAge provides a tool kit for the Banshee BN15. This kit contains required wrenches for the BN13 swivel.

SWIVEL	TOOL KIT	MANUAL
BN15 (22k)	BN15 612	PL 505

Kit components and tool maintenance/assembly videos are available on the StoneAge website:

WWW.STONEAGETOOLS.COM

For questions or help with a specific application, configuration or tool repairs, please contact your StoneAge Customer Service.

When ordering a Banshee BN15 tool by line item, you should specify:

1. Swivel Part ID
2. Head Part ID
3. Part IDs of spare heads or maintenance items, if required

FOR EXAMPLE:

QTY	PART ID	DESCRIPTION
1	BN15-P2	Banshee swivel 13 mm 1/8 NPT connection
3	BN15 042-A	Polisher head
2	BN15 044-A	Universal head

BANSHEE BN18

ORDERING A STANDARD PACKAGE

StoneAge offers standardized Banshee BN18 tool packages for the most commonly used configurations. All Banshee BN18 packages come fully assembled and include 1. Swivel, 2. Head.

The following table shows the configurations of standard Banshee BN18 tool packages:

MAXIMUM PRESSURE	INLET CONNECTION	PACKAGE CONTENTS	PACKAGE PART ID
15k psi 1000 bar	1/4 NPT Female	1 x BN18 Banshee swivel 1 x Polisher head	BN18-NPT-POL-PKG
		1 x BN18 Banshee swivel 1 x Universal head	BN18-NPT-UNI-PKG
		1 x BN18 Banshee swivel 1 x Unplugger head	BN18-NPT-UNP-PKG
20k psi 1400 bar	1/4 BSPP Female	1 x BN18 Banshee swivel 1 x Polisher head	BN18-BSPP-POL-PKG
		1 x BN18 Banshee swivel 1 x Universal head	BN18-BSPP-UNI-PKG
		1 x BN18 Banshee swivel 1 x Unplugger head	BN18-BSPP-UNP-PKG
22k psi 1500 bar	9/16 LH Female, 9/16 RH Female	1 x BN18 Banshee swivel 1 x Polisher head	BN18-MP-POL-PKG
		1 x BN18 Banshee swivel 1 x Universal head	BN18-MP-UNI-PKG
		1 x BN18 Banshee swivel 1 x Unplugger head	BN18-MP-UNP-PKG
40k psi 2800 bar	3/8 LH Female, M14 LH Female, 9/16 LH Female, 9/16 RH Female	1 x BN18 Banshee swivel 1 x Polisher head	BN18-HP-POL-PKG
		1 x BN18 Banshee swivel 1 x Unplugger head	BN18-HP-UNP-PKG

When ordering a standard Banshee BN18 package, you should specify:

1. Package Part ID and inlet connection thread
2. Pump pressure and flow
3. Hose length and ID

FOR EXAMPLE:

QTY	PART ID	DESCRIPTION
1	BN18-HP-POL-PKG	BN18 polisher package 40k psi 6 gpm 30 ft 5 mm ID hose 3/8 LH

ORDERING BY LINE ITEM

Complete tools can be configured by following the steps outlined below.
Contact your StoneAge Customer Service for questions about specific applications.

STEP 1 SWIVEL SELECTION

There are six Banshee BN18 swivel options available. The correct swivel is selected based on the maximum working pressure and inlet connection required.

MAXIMUM PRESSURE	INLET CONNECTION	SWIVEL PART ID
15k psi 1000 bar	1/4 NPT Female	BN18-P4
20k psi 1400 bar	1/4 BSPP Female	BN18-BSPP4
22k psi 1500 bar	9/16 LH Female	BN18-MP9L
	9/16 RH Female	BN18-MP9R
40k psi 2800 bar	3/8 LH Female	BN18-H6L
	M14 LH Female	BN18-HM14L
	9/16 LH Female	BN18-H9L
	9/16 RH Female	BN18-H9R

STEP 2 HEAD SELECTION

There are three standard head configurations for the BN18 swivel. Custom heads are available on request.

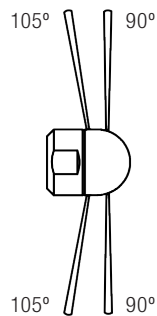

POLISHER

4 Ports:
2 @ 90°
2 @ 105°

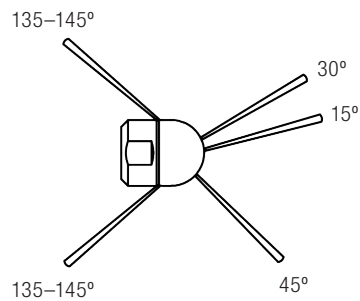

UNPLUGGER

5 Ports:
1 @ 15°
1 @ 30°
1 @ 45°
2 @ 135° or 145°

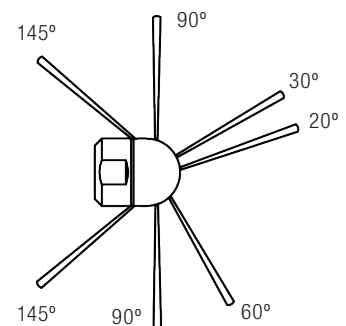

UNIVERSAL

7 Ports:
1 @ 20°
1 @ 30°
1 @ 60°
2 @ 90°
2 @ 145°

BANSHEE BN18

The following table lists head selection approximations of common jetting scenarios for Banshee BN18 swivels:

SWIVEL	HEAD STYLE	PRESSURE RANGE	FLOW RANGE	HEAD PART ID	NOZZLES FITTED	
					FRONT	BACK
BN18	Polisher	8–15k psi 550–1000 bar	11–14 gpm 42–53 l/min	BN18 042-A	N/A	N/A
			8–10 gpm 30–38 l/min	BN18 042-B	N/A	N/A
		12–22k psi 830–1500 bar	11–14 gpm 42–53 l/min	BN18 042-C	N/A	N/A
			8–10 gpm 30–38 l/min	BN18 042-D	N/A	N/A
		30–40k psi 2100–2800 bar	8–8.5 gpm 30–32 l/min	BN18 442-A	2 x OS2 020	2 x OS2 017
			7–7.5 gpm 27–28 l/min	BN18 442-B	2 x OS2 018	2 x OS2 017
			6–6.5 gpm 23–25 l/min	BN18 442-C	2 x OS2 015	2 x OS2 015
			5–5.5 gpm 19–21 l/min	BN18 442-D	2 x OS2 010	2 x OS2 014
	Unplugging	8–15k psi 550–1000 bar	11–14 gpm 42–53 l/min	BN18 043-A	N/A	N/A
			8–10 gpm 30–38 l/min	BN18 043-B	N/A	N/A
		12–22k psi 830–1500 bar	11–14 gpm 42–53 l/min	BN18 043-C	N/A	N/A
			8–10 gpm 30–38 l/min	BN18 043-D	N/A	N/A
		30–40k psi 2100–2800 bar	8–8.5 gpm 30–32 l/min	BN18 443-A	3 x OS2 014	2 x OS2 020
			7–7.5 gpm 27–28 l/min	BN18 443-B	3 x OS2 013	2 x OS2 019
			6–6.5 gpm 23–25 l/min	BN18 443-C	3 x OS2 011	2 x OS2 016
			5–5.5 gpm 19–21 l/min	BN18 443-D	3 x OS2 009	2 x OS2 014
	Universal	8–15k psi 550–1000 bar	11–15 gpm 42–53 l/min	BN18 044-A	N/A	N/A
			8–10 gpm 30–38 l/min	BN18 044-B	N/A	N/A
		12–22k psi 830–1500 bar	11–14 gpm 42–53 l/min	BN18 044-C	N/A	N/A

STEP 3 MAINTENANCE RESOURCES

StoneAge provides a tool kit for the Banshee BN18. This kit contains required wrenches for the BN18 swivel.

SWIVEL	TOOL KIT	MANUAL
BN18 (22k)	BN18 612	PL 505
BN18 (40k)	BN18 612-H	PL 507

Kit components and tool maintenance/assembly videos are available on the StoneAge website:

WWW.STONEAGETOOLS.COM

For questions or help with a specific application, configuration or tool repairs, please contact your StoneAge Customer Service.

When ordering a Banshee BN18 tool by line item, you should specify:

1. Swivel Part ID
2. Head Part ID
3. Part IDs of spare heads or maintenance items, if required

FOR EXAMPLE:

QTY	PART ID	DESCRIPTION
1	BN18-HM14L	Banshee swivel 18 mm M14 LH connection
3	BN18 442-A	Polisher head

BANSHEE BN24

ORDERING A STANDARD PACKAGE

StoneAge offers standardized Banshee BN24 tool packages for the most commonly used configurations. All Banshee BN24 packages come fully assembled and include 1. Swivel, 2. Head.

The following table shows the configurations of standard Banshee BN24 tool packages:

MAXIMUM PRESSURE	INLET CONNECTION	PACKAGE CONTENTS	PACKAGE PART ID
15k psi 1000 bar	3/8 NPT Female	1 x BN24 Banshee swivel 1 x Polisher head	BN24-NPT-POL-PKG
		1 x BN24 Banshee swivel 1 x Universal head	BN24-NPT-UNI-PKG
20k psi 1400 bar	3/8 BSPP Female	1 x BN24 Banshee swivel 1 x Polisher head	BN24-BSPP-POL-PKG
		1 x BN24 Banshee swivel 1 x Universal head	BN24-BSPP-UNI-PKG
22k psi 1500 bar	9/16 LH Female, 9/16 RH Female	1 x BN24 Banshee swivel 1 x Polisher head	BN24-MP-POL-PKG
		1 x BN24 Banshee swivel 1 x Universal head	BN24-MP-UNI-PKG

When ordering a standard Banshee BN24 package, you should specify:

1. Package Part ID and inlet connection thread
2. Pump pressure and flow
3. Hose length and ID

FOR EXAMPLE:

QTY	PART ID	DESCRIPTION
1	BN24-MP-POL-PKG	BN24 polisher package 20k psi 16 gpm 50 ft 10 mm ID hose 9/16 LH

ORDERING BY LINE ITEM

Complete tools can be configured by following the steps outlined below.
Contact your StoneAge Customer Service for questions about specific applications.

STEP 1 SWIVEL SELECTION

There are four Banshee BN24 swivel options available. The correct swivel is selected based on the maximum working pressure and inlet connection required.

MAXIMUM PRESSURE	INLET CONNECTION	SWIVEL PART ID
15k psi 1000 bar	3/8 NPT Female	BN24-P6
20k psi 1400 bar	3/8 BSPP Female	BN24-BSPP
22k psi 1500 bar	9/16 LH Female	BN24-MP9L
	9/16 RH Female	BN24-MP9R

STEP 2 HEAD SELECTION

There are three standard head configurations for the BN24 swivel. Custom heads are available on request.

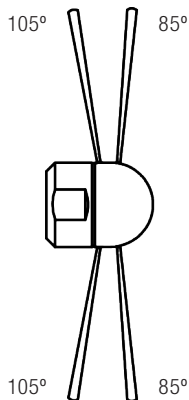

POLISHER

2 Ports:
2 @ 85°
2 @ 105°

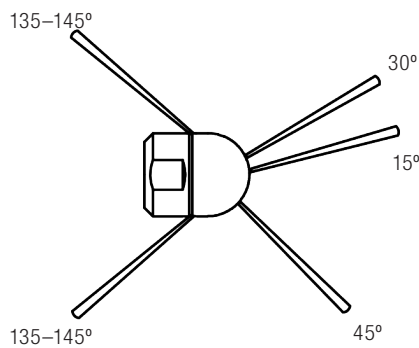

UNPLUGGER

5 Ports:
1 @ 15°
1 @ 30°
1 @ 45°
2 @ 135° or 145°

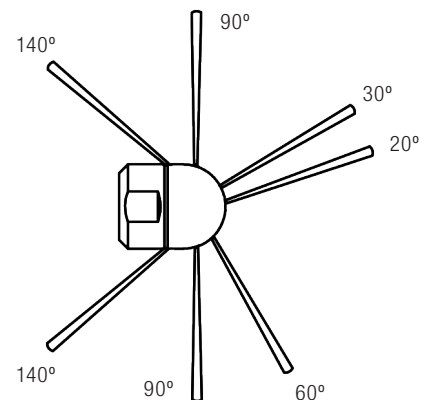

UNIVERSAL

7 Ports:
1 @ 20°
1 @ 30°
1 @ 60°
2 @ 90°
2 @ 140°

BANSHEE BN24

The following table lists head selection approximations of common jetting scenarios for Banshee BN24 swivels:

SWIVEL	HEAD STYLE	PRESSURE RANGE	FLOW RANGE	HEAD PART ID
BN24	Polisher	8–15k psi 550–1000 bar	19–24 gpm 72–91 l/min	BN24 042-A
			14–18 gpm 53–68 l/min	BN24 042-B
			11–13 gpm 42–49 l/min	BN24 042-C
		12–22k psi 830–1500 bar	17–20 gpm 64–76 l/min	BN24 042-D
			14–16 gpm 53–61 l/min	BN24 042-E
			11–13 gpm 42–49 l/min	BN24 042-F
	Unplugging	8–15k psi 550–1000 bar	19–24 gpm 72–91 l/min	BN24 043-A
			14–18 gpm 53–68 l/min	BN24 043-B
			11–13 gpm 42–49 l/min	BN24 043-C
		12–22k psi 830–1500 bar	17–20 gpm 64–76 l/min	BN24 043-D
			14–16 gpm 53–61 l/min	BN24 043-E
			11–13 gpm 42–49 l/min	BN24 043-F
	Universal	10–15k psi 700–1000 bar	19–24 gpm 72–91 l/min	BN24 044-A
			14–18 gpm 53–68 l/min	BN24 044-B
			11–13 gpm 42–49 l/min	BN24 044-C
		15–22k psi 1000–1500 bar	17–20 gpm 64–76 l/min	BN24 044-D
			14–16 gpm 53–61 l/min	BN24 044-E
			11–13 gpm 42–49 l/min	BN24 044-F

STEP 3 MAINTENANCE RESOURCES

StoneAge provides a tool kit for the Banshee BN24. This kit contains required wrenches for the BN24 swivel.

SWIVEL	TOOL KIT	MANUAL
BN24 (22k)	BN24 612	PL 505

Kit components and tool maintenance/assembly videos are available on the StoneAge website:

WWW.STONEAGETOOLS.COM

When ordering a Banshee BN24 tool by line item, you should specify:

1. Swivel Part ID
2. Head Part ID
3. Part IDs of spare heads or maintenance items, if required

FOR EXAMPLE:

QTY	PART ID	DESCRIPTION
1	BN24-P6	Banshee swivel 24 mm 3/8 NPT connection
3	BN24 044-E	Polisher head
1	BN24 612	Tool Kit

BANSHEE BN27

ORDERING A STANDARD PACKAGE

StoneAge offers standardized Banshee BN27 tool packages for the most commonly used configurations. All Banshee BN27 packages come fully assembled and include 1. Swivel, 2. Head.

The following table shows the configurations of standard Banshee BN27 tool packages:

MAXIMUM PRESSURE	INLET CONNECTION	PACKAGE CONTENTS	PACKAGE PART ID
40k psi 2800 bar	9/16 LH Female	1 x BN27 Banshee swivel 1 x Polisher head	BN27-HP-POL-PKG
		1 x BN27 Banshee swivel 1 x Unplugging head	BN27-HP-UNP-PKG
	M14 LH Female	1 x BN27 Banshee swivel 1 x Polisher head	BN27-MHP-POL-PKG
		1 x BN27 Banshee swivel 1 x Unplugging head	BN27-MHP-UNP-PKG

When ordering a standard Banshee BN27 package, you should specify:

1. Package Part ID and inlet connection thread
2. Pump pressure and flow
3. Hose length and ID

FOR EXAMPLE:

QTY	PART ID	DESCRIPTION
1	BN27-HP-POL-PKG	BN27 polisher package 40k psi 7.5 gpm 50 ft 8 mm ID hose 9/16 LH

BANSHEE BN27

ORDERING BY LINE ITEM

Complete tools can be configured by following the steps outlined below.
 Contact your StoneAge Customer Service for questions about specific applications.

STEP 1 SWIVEL SELECTION

There are two Banshee BN27 swivel options available. The correct swivel is selected based on the maximum working pressure and inlet connection required.

MAXIMUM PRESSURE	INLET CONNECTION	SWIVEL PART ID
40k psi 2800 bar	9/16 LH Female	BN27-H9L
	M14 LH Female	BN27-HM14L

STEP 2 HEAD SELECTION

There are two standard head configurations for the BN27 swivel. Custom heads are available on request.

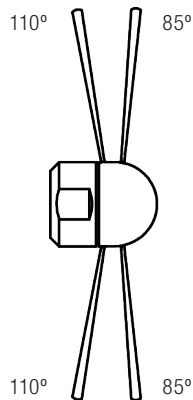

POLISHER

4 Ports:
 2 @ 85°
 2 @ 110°

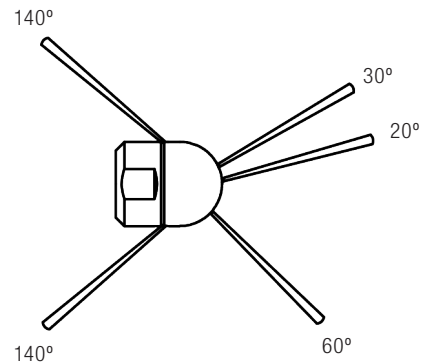

UNPLUGGER

5 Ports:
 1 @ 20°
 1 @ 30°
 1 @ 60°
 2 @ 140°

The following table lists head selection approximations of common jetting scenarios for Banshee BN27 swivels:

SWIVEL	HEAD STYLE	PRESSURE RANGE	FLOW RANGE	HEAD PART ID	NOZZLES FITTED	
					FRONT	BACK
BN27	Polisher	30–40k psi 2100–2800 bar	8–8.5 gpm 30–32 l/min	BN27 442-A	2 x OS2 018	2 x OS2 018
			7–7.5 gpm 27–28 l/min	BN27 442-B	2 x OS2 015	2 x OS2 016
			6–6.5 gpm 23–25 l/min	BN27 442-C	2 x OS2 011	2 x OS2 015
			5–5.5 gpm 19–21 l/min	BN27 442-D	2 x OS2 009	2 x OS2 013
	Unplugging	30–40k psi 2100–2800 bar	8–8.5 gpm 30–32 l/min	BN27 443-A	3 x OS2 013	2 x OS2 019
			7–7.5 gpm 27–28 l/min	BN27 443-B	3 x OS2 011	2 x OS2 017
			6–6.5 gpm 23–25 l/min	BN27 443-C	3 x OS2 009	2 x OS2 014
			5–5.5 gpm 19–21 l/min	BN27 443-D	3 x OS2 006	2 x OS2 013

STEP 3 MAINTENANCE RESOURCES

StoneAge provides a tool kit for the Banshee BN27. This kit contains required wrenches for the BN27 swivel.

SWIVEL	TOOL KIT	MANUAL
BN27 (40k)	BN27 6120H9L	PL 507

Kit components and tool maintenance/assembly videos are available on the StoneAge website:

WWW.STONEAGETOOLS.COM

For questions or help with a specific application, configuration or tool repairs, please contact your StoneAge Customer Service.

When ordering a Banshee BN27 tool by line item, you should specify:

1. Swivel Part ID
2. Head Part ID
3. Part IDs of spare heads or maintenance items, if required

FOR EXAMPLE:

QTY	PART ID	DESCRIPTION
1	BN27-H9L	Banshee swivel 27 mm 9/16 LH connection
3	BN27 443-C	Unplugging head

BANSHEE BN33

ORDERING A STANDARD PACKAGE

StoneAge offers standardized Banshee BN33 tool packages for the most commonly used configurations. All Banshee BN33 packages come fully assembled and include 1. Swivel, 2. Head.

The following table shows the configurations of standard Banshee BN33 tool packages:

MAXIMUM PRESSURE	INLET CONNECTION	PACKAGE CONTENTS	PACKAGE PART ID
15k psi 1000 bar	1/2 NPT Female	1 x BN33 Banshee swivel 1 x Universal head	BN33-NPT-UNI-PKG
22k psi 1500 bar	1/2 BSP Female	1 x BN33 Banshee swivel 1 x Universal head	BN33-BSPP-UNI-PKG
	9/16 MP Female	1 x BN33 Banshee swivel 1 x Universal head	BN33-MP-UNI-PKG

When ordering a standard Banshee BN33 package, you should specify:

1. Package Part ID and inlet connection thread
2. Pump pressure and flow
3. Hose length and ID

FOR EXAMPLE:

QTY	PART ID	DESCRIPTION
1	BN33-MP-UNI-PKG	BN33 universal package 9/16 MP inlet 15k psi 15 gpm 50 ft 10 mm ID hose

ORDERING BY LINE ITEM

Complete tools can be configured by following the steps outlined below.
Contact your StoneAge Customer Service for questions about specific applications.

STEP 1 SWIVEL SELECTION

There are six Banshee BN33 swivel options available. The correct swivel is selected based on the maximum working pressure and inlet connection required.

MAXIMUM PRESSURE	INLET CONNECTION	SWIVEL PART ID
15k psi 1000 bar	1/2 NPT Female	BN33-P8
22k psi 1500 bar	1/2 BSPP Female	BN33-BSPP8
	9/16 MP Female	BN33-MP9

STEP 2 HEAD SELECTION

There is one standard head configurations for the BN33 swivel. Custom heads are available on request.

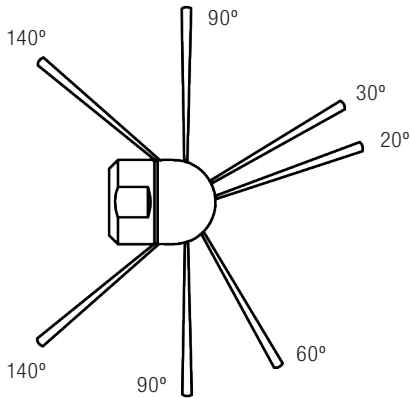

UNIVERSAL

7 Ports:
1 @ 20°
1 @ 30°
1 @ 60°
2 @ 90°
2 @ 140°

BANSHEE BN33

The following table lists head selection approximations of common jetting scenarios for Banshee BN33 swivels:

SWIVEL	HEAD STYLE	PRESSURE RANGE	FLOW RANGE	HEAD PART ID
BN33	Universal	8–15k psi 550–1000 bar	39–48 gpm 148–182 l/min	BN33 044-A
			32–38 gpm 121–142 l/min	BN33 044-B
			25–31 gpm 95–117 l/min	BN33 044-C
			19–24 gpm 72–91 l/min	BN33 044-D
			14–18 gpm 53–68 l/min	BN33 044-E
		12–22k psi 830–1500 bar	21–25 gpm 79–95 l/min	BN33 044-F
			17–20 gpm 64–76 l/min	BN33 044-G
			14–16 gpm 53–61 l/min	BN33 044-H
			11–13 gpm 42–49 l/min	BN33 044-I

STEP 3 MAINTENANCE RESOURCES

StoneAge provides a tool kit for the Banshee BN33. This kit contains required wrenches for the BN33 swivel.

SWIVEL	TOOL KIT	MANUAL
BN33 (22k)	BN33 612	PL 505

Kit components and tool maintenance/assembly videos are available on the StoneAge website:

WWW.STONEAGETOOLS.COM

For questions or help with a specific application, configuration or tool repairs, please contact your StoneAge Customer Service.

When ordering a Banshee BN33 tool by line item, you should specify:

1. Swivel Part ID
2. Head Part ID
3. Part IDs of spare heads or maintenance items, if required

FOR EXAMPLE:

QTY	PART ID	DESCRIPTION
1	BN33-P8	Banshee swivel 33 mm 1/2 NPT connection
3	BN33 044-C	Universal head