

# BEETLE

## Rotary Cleaning for Curved Pipes/Tubes

Actual tool size shown

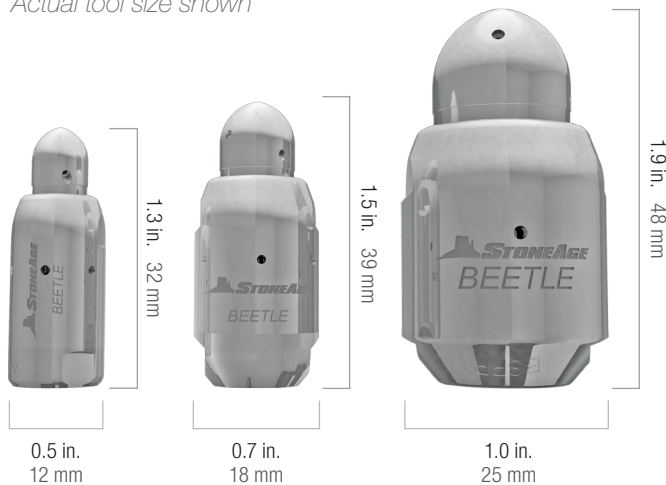

### OVERVIEW

The Beetle line of rotary tools leverage off the same patented technology that has made Banshee nozzles the most successful tube cleaning tools in the industry. Beetle nozzles are engineered to provide the same powerful cleaning features, but in a compact size that is ideal for navigating tubes and small pipes with curves and elbows.

The small diameter and short length of Beetle tools make them perfect for use with a Navigator, AutoBox ProDrive or Boiler Tube Cleaner for cleaning process piping, drain lines, u-tube bundles and other small ID conduit with bends that may have been inaccessible in the past.

### COMPETITIVE ADVANTAGES

- Small size allows the Beetle to navigate tight curves in small diameter pipe
- Low cost, low maintenance design
- Perfect nozzle to pair with ABX-2L, AutoBox ProDrive, or StoneAge Boiler Tube Cleaner
- Can be combined with the Navigator for hose rotation enabling access through multiple bends

FEATURES	BENEFITS
<ul style="list-style-type: none"> <li>• Rotating head</li> </ul>	<ul style="list-style-type: none"> <li>• Better jet coverage and more efficient cleaning than a static head</li> </ul>
<ul style="list-style-type: none"> <li>• Short tool length</li> </ul>	<ul style="list-style-type: none"> <li>• Allows Beetle to pass bends and elbows to clean tubes that may otherwise be inaccessible</li> </ul>
<ul style="list-style-type: none"> <li>• Small diameter</li> </ul>	<ul style="list-style-type: none"> <li>• Clean tubes with internal diameters as small as 5/8 in. (16 mm)</li> <li>• Accept jobs where small tube size has been a barrier</li> </ul>
<ul style="list-style-type: none"> <li>• Patented liquid bearing technology</li> </ul>	<ul style="list-style-type: none"> <li>• No bearings, seals or lubricant to replace — reduced maintenance costs</li> </ul>
<ul style="list-style-type: none"> <li>• Recessed inlet design</li> </ul>	<ul style="list-style-type: none"> <li>• Retains short rigid length when coupled with hose</li> </ul>
<ul style="list-style-type: none"> <li>• Up to 22k psi (1500 bar) MAWP</li> </ul>	<ul style="list-style-type: none"> <li>• Ideal for removing scale, carbons and polymers</li> </ul>

## QUESTIONS TO ASK YOUR CUSTOMER

- What size and length of hose are you using?
- What pressure and flow are you operating?
- What are the length, diameter and curve radius of the tubes?
- What is the curve radius of the tubes?
- What type of cleaning is required? Are the tubes plugged?
- Do you need a backout preventer?  
*You should always use a backout preventer with high pressure tube cleaning tools.*

## TOOL SPECIFICATIONS

PART ID	BT12	BT18	BT25
<b>Pipe/Tube ID Range</b>	0.6–1.0 in. 15–25 mm	0.9–1.3 in. 22–33 mm	1.2–3.0 in. 30–76 mm
<b>Pressure Range</b>	10–22k psi 700–1500 bar	10–22k psi 700–1500 bar	8–22k psi 550–1500 bar
<b>Flow Range</b>	6.5–8.5 gpm 25–32 l/min	8.5–11 gpm 32–42 l/min	8–20 gpm 30–76 l/min
<b>Flow Coefficient</b>	0.25 Cv	0.25 Cv	0.45 Cv
<b>Pulling Force</b>	9.0 lb @ 15k psi 4.1 kg @ 1000 bar	10.5 lb @ 15k psi 4.7 kg @ 1000 bar	12 lb @ 15k psi 5.5 kg @ 1000 bar
<b>Inlet Connections</b>	P1, M7, MP4L, MP4R	P1, P2, BSPP2, MP6L, MP6R, MP4L, MP4R	1/8 NPT, 1/4 NPT, 1/4 BSPP, 3/8-28 LH/RH, 9/16-18 LH/RH
<b>Diameter</b>	0.5 in. 12 mm	0.7 in. 18 mm	1.0 in. 26 mm
<b>Length</b>	1.3 in. 32 mm	1.5 in. 39 mm	1.9 in. 48 mm
<b>Maximum Water Temperature</b>	250 °F 120 °C	250 °F 120 °C	250 °F 120 °C

## OTHER INFORMATION

- We recommend that the entire system be flushed out before installing the Beetle on the end of the hose or stinger. The swivels require a clean water supply for reliable operation; filtration to 25 micron particulates or smaller is recommended.
- When using rotating nozzles in plugged tubes, do not jam the head into the deposit because this will stop the rotation of the tool and impede the cutting ability. When the tool contacts the deposit, allow it to cut away the material and advance at its own rate. If it stops advancing, pull back slightly on the hose to move the head away from the deposit. This action also allows the jets to cut the deposit at different angles.
- Water must be blown out of the Beetle after each use to avoid corrosion damage. It is also important to soak or bathe the tool in a very light oil such as WD-40® between applications.
- The use of pipe wrenches and or pliers with “teeth” will void all tool warranty. All Banshee tube cleaning tools require the use of a correctly sized open-end wrench to fit the flats provided on the inlet nut when attaching the tool to the lance. Incorrect tools can crush or crack the hardened steel body, leading to failure or breakage during operation.
- It is important to consider the length of your hose crimp and avoid couplings and adapters when configuring the Beetle to best take advantage of the small profile when cleaning tubes with bends or elbows. The following table illustrates minimum tube size and bend radius specifications for common applications:

APPLICATION	TOOL MODEL	MINIMUM TUBE ID	MINIMUM RADIUS
15k psi/P1 on 3 mm Hose	<b>BT12</b>	0.63 in. 16 mm	2.5 in. 64 mm
		0.75 in. 19 mm	2.0 in. 51 mm
	<b>BT18</b>	0.75 in. 19 mm	3.0 in. 76 mm
		1.0 in. 25 mm	2.0 in. 51 mm
	<b>BT25</b>	1.25 in. 32 mm	3.0 in. 76 mm
		1.5 in. 38 mm	2.0 in. 51 mm
15k psi/P2 on 5 mm Hose	<b>BT18</b>	1.0 in. 25 mm	3.0 in. 76 mm
	<b>BT25</b>	1.25 in. 32 mm	3.0 in. 76 mm
20k psi/L4 on 5 mm Hose	<b>BT12</b>	0.75 in. 19 mm	5.0 in. 127 mm
		1.0 in. 25 mm	3.0 in. 76 mm
	<b>BT18</b>	1.6 in. 41 mm	2.5 in. 64 mm
	<b>BT25</b>	1.6 in. 41 mm	2.5 in. 64 mm

Visit our website for tool resources including operation and maintenance videos:

**WWW.STONEAGETOOLS.COM**

## BEETLE TOOL CONFIGURATION

---

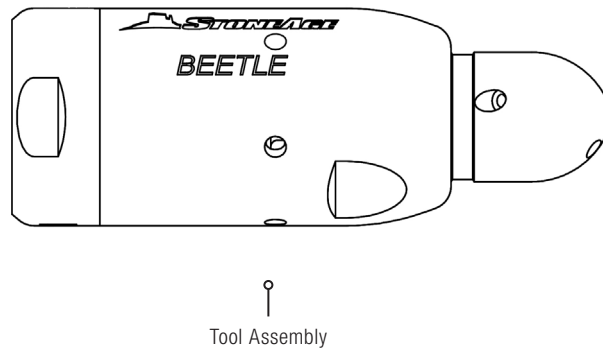

---

**A complete Beetle tool configuration requires the following components:**

1. Tool for required working pressure and inlet connection

**The following items may also be required:**

- Backout preventer

**To configure a Beetle tool, the following information should be obtained:**

- Pump pressure and flow
- Hose length and ID
- Hose/lance end fitting

## ORDERING A BEETLE

Complete tools can be configured by following the steps outlined below.

STEP 1		TOOL SELECTION			
TUBE SIZE	MAXIMUM PRESSURE	FLOW RANGE	INLET CONNECTION	TOOL PART ID	
0.6–1.0 in. 15–25 mm	15k psi 1000 bar	6.5–8.5 gpm 25–32 l/min	1/16 NPT	<b>BT12-P1-B</b>	
	22k psi 1500 bar	6.5–8.5 gpm 25–32 l/min	M7-1.0	<b>BT12-M7-B</b>	
		6.5–8.5 gpm 25–32 l/min	1/4-28 LH	<b>BT12-MP4L-B</b>	
		6.5–8.5 gpm 25–32 l/min	1/4-28 RH	<b>BT12-MP4R-B</b>	
0.9–1.3 in. 22–33 mm	15k psi 1000 bar	8.5–11 gpm 32–42 l/min	1/16 NPT	<b>BT18-P1-A</b>	
		8.5–11 gpm 32–42 l/min	1/8 NPT	<b>BT18-P2-A</b>	
	18k psi 1250 bar	8.5–11 gpm 32–42 l/min	1/8 BSPP	<b>BT18-BSPP2-A</b>	
	22k psi 1500 bar	8.5–11 gpm 32–42 l/min	1/4-28 LH	<b>BT18-MP4L-A</b>	
		8.5–11 gpm 32–42 l/min	1/4-28 RH	<b>BT18-MP4R-A</b>	
		8.5–11 gpm 32–42 l/min	3/8-24 LH	<b>BT18-MP6L-A</b>	
		8.5–11 gpm 32–42 l/min	3/8-24 RH	<b>BT18-MP6R-A</b>	
1.2–3.0 in. 30–76 mm	15k psi 1000 bar	12–16 gpm 45–60 l/min	1/8 NPT	<b>BT25-P2-A</b>	
		12–16 gpm 45–60 l/min	1/4 NPT	<b>BT25-P4-A</b>	
	20.3k psi 1400 bar	16–20 gpm 60–76 l/min	1/4 BSPP	<b>BT25-BSPP4-A</b>	
	22k psi 1500 bar	16–20 gpm 60–76 l/min	3/8-24 Left Hand	<b>BT25-MP6L-A</b>	
		16–20 gpm 60–76 l/min	3/8-24 Right Hand	<b>BT25-MP6R-A</b>	
		16–20 gpm 60–76 l/min	9/16-18 Left Hand	<b>BT25-MP9L-A</b>	
		16–20 gpm 60–76 l/min	9/16-18 Right Hand	<b>BT25-MP9R-A</b>	
	15k psi 1000 bar	8–11 gpm 30–41 l/min	1/8 NPT	<b>BT25-P2-C</b>	
		8–11 gpm 30–41 l/min	1/4 NPT	<b>BT25-P4-C</b>	
	20.3k psi 1400 bar	11–13 gpm 41–49 l/min	1/4 BSPP	<b>BT25-BSPP4-C</b>	
	22k psi 1500 bar	11–13 gpm 41–49 l/min	3/8-24 Left Hand	<b>BT25-MP6L-C</b>	
		11–13 gpm 41–49 l/min	3/8-24 Right Hand	<b>BT25-MP6R-C</b>	
		11–13 gpm 41–49 l/min	9/16-18 Left Hand	<b>BT25-MP9L-C</b>	
		11–13 gpm 41–49 l/min	9/16-18 Right Hand	<b>BT25-MP9R-C</b>	

# BEETLE TOOL CONFIGURATION

## STEP 2 MAINTENANCE RESOURCES

StoneAge provides a tool kit for the Beetle. This kit contains required wrenches for the Beetle swivel.

TOOL MODEL	TOOL KIT	MANUAL
BT12	BT12 612	PL 601
BT18	BT18 612	PL 601
BT25	BT25 612	PL 601

Kit components and tool maintenance/assembly videos are available on our website:

**[WWW.STONEAGETOOLS.COM](http://WWW.STONEAGETOOLS.COM)**

### When ordering a Beetle tool, you should specify:

1. Tool Part ID
2. Part IDs of maintenance items, if required

FOR EXAMPLE:

Beetle for cleaning 1-inch diameter tube at 22k psi with a 1/4" right hand inlet

QTY	PART ID	DESCRIPTION
1	BT18-MP4R-A	Beetle Tube Spinner, 22k psi (8.5-11gpm)